

# RE-428DU-C

## CONVENTIONAL DUCT OPTICAL SMOKE DETECTOR

### General

This Duct detector can be installed on any side of the duct. RE-428DU-C contains an intelligent controlling circuit. The circuit adjusts the sensitivity to give an optimal function throughout the entire life of the detector. Advanced Venturi tube technology with single tube detector. This duct detector housed with the flow optimization and two feet sampling pipe.

### Features

- High efficient single sampling tube.
- Easy to install.
- One-pipe air sampling system.
- Patented venturi pipe and duct housing.
- Test hole on cover.
- Simple installation.
- Simple service and maintenance.



### Specification

	Electrical Specification
<i>Operating Voltage</i>	9 ~ 33 VDC
<i>Operating Temperature</i>	-10 – 37.8° C
<i>Storage Temperature</i>	-10 – 60° C
<i>Humidity</i>	0 - 95% RH, non-condensing
<i>Reset Voltage</i>	Less than 1V
<i>Standby Current</i>	50 µA
<i>Alarm Current</i>	40 mA (max)
<i>Remote Output</i>	15mA maximum open collector
<i>Smoke Sensitivity</i>	(1.96 ± 0.76) % / ft
<i>Air Velocity</i>	0 – 4000 fpm.
<i>Dimensions</i>	(241 L X 195 W X 68 D) mm
<i>Weight</i>	1.04 kg
<i>Air Sampling Tube</i>	Aluminium (Hole Diameter 1.5" (38 mm)).

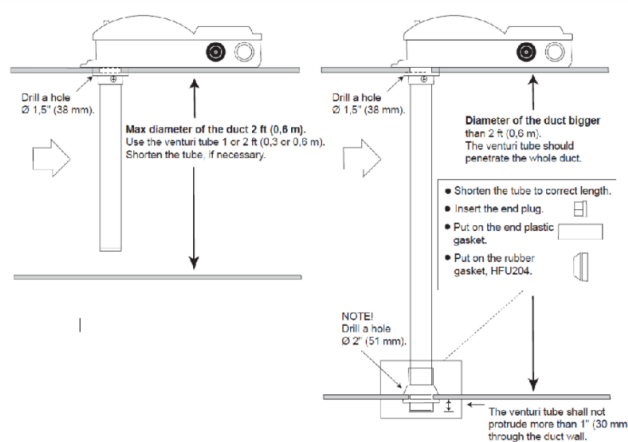

#### DIMENSIONS Inches / (mm)

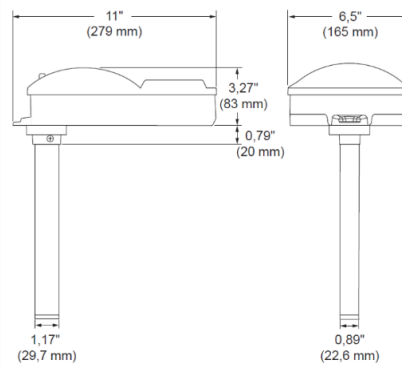

## Compatible Panel

Model	Description
RE-102	Conventional 2 IDC Fire Alarm Control Panel
RE-104	Conventional 4 IDC Fire Alarm Control Panel
RE-2554	Conventional 4 IDC Fire Alarm Control Panel
RE-2558	Conventional 8 IDC Fire Alarm Control Panel
RE-900 Series	Conventional Fire Alarm Control Panel
RE-25AR	Conventional Agent Release Control Panel
RE-120GR	Conventional Gas Release Control Panel

## Ordering Information

Model	Description
RE-428DU-C	Single tube Conventional Duct Detector
RE-428DU-S2	Sampling tube length: 2 ft (0.6 m)

### India

RAVEL ELECTRONICS PVT LTD.,  
150A, Electronics Industrial Estate,  
Perungudi, Chennai – 96, India.  
E-mail: [marketing@ravelfire.com](mailto:marketing@ravelfire.com); Web: [www.ravelfire.com](http://www.ravelfire.com)

### United Kingdom

RAVEL ELECTRONICS LTD.,  
Unit 11, Chancel Industrial Estate, Newhall street,  
Willenhall WV13 1NX, West Midlands, United Kingdom.  
E-mail: [info@ravelfire.co.uk](mailto:info@ravelfire.co.uk); Web: [www.ravelfire.co.uk](http://www.ravelfire.co.uk)

### USA

RAVEL AMERICAS INC.,  
2855 NW 112<sup>th</sup> Ave ST#2 Miami,  
Doral, Florida 33172, USA.