

RE-717MM

ADDRESSABLE MONITOR MODULE

General

Monitor Module is an input module facilitates to interface with third party devices like security contacts, waterflow switches, pull stations, etc. with Fire Alarm Control Panel. The RED blinking LED indicates normal operating conditions and the steady state LED for activated conditions. DIP switches are provided for addressing of the module. The Monitor circuit is supervised for faulty condition.



Features

- UL-Listed (9th Edition).
- CE Approved.
- Modular Construction.
- Module Status by RED LED.
- Analogue Communication with the panel.
- Addressing by 8 way DIP switches.
- Low Standby Current.
- Available with suitable back boxes.



Specification

Electrical Specification	
Operating Voltage	24 VDC Nominal.
Alarm Current	2.7 mA Max.(Latched)
Standby Current	700 μ A
Input	End of Line Resistor 47K Ohms
	Wiring Resistance 100 Ohms Max
	Voltage 8 V Max
Operating Temperature	0°C to 49°C / 32°- 120°F
Storage Temperature	0°C to 60°C
Humidity	93 \pm 2% RH (non-condensing) at 32 \pm 2° C / 90 \pm 3° F
Mechanical Specification	
Dimensions	(95 W X 75 H X 24D) mm
Color	Black
Material	FR ABS plastic
Weight	0.35 Kg

Dimensions

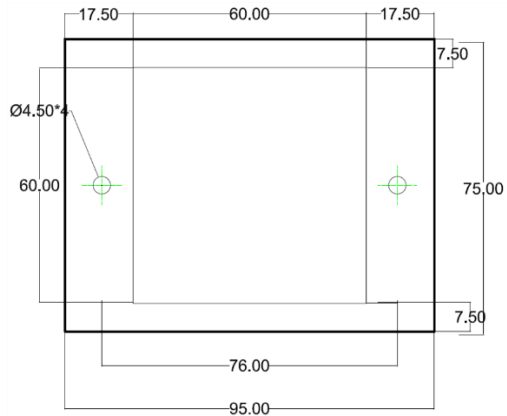
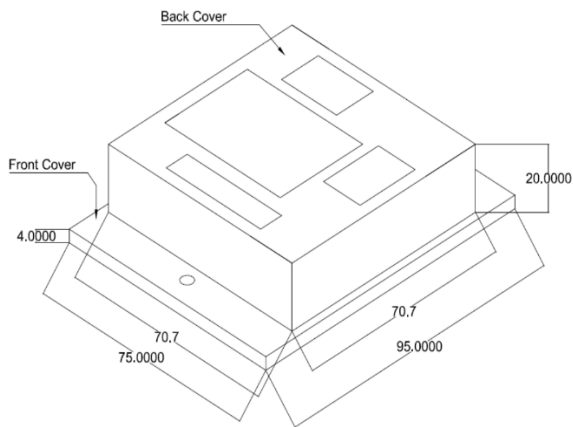

Wiring Configuration

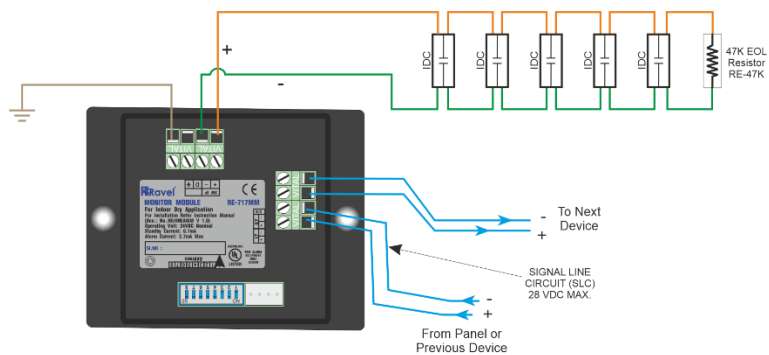

Use only Listed Compatible Panel

NOTE:

* D = NO CONNECTION

* ALL WIRING SHOWN IS SUPERVISED AND POWER LIMITED

Compatible Device

Model	Description
<i>Avani</i>	Analogue addressable Fire Alarm Control panel expandable upto 4 loop
<i>Avani db</i>	Analogue Addressable Fire Alarm Control panel expandable upto 2 loop
<i>Avani XL</i>	Analogue Addressable Fire Alarm Control Panel expandable upto 8 Loop

Ordering Information

Models	Description
RE-717MM	Addressable Monitor Module

India

RAVEL ELECTRONICS PVT LTD.,
150A, Electronics Industrial Estate,
Perungudi, Chennai – 96, India.
E-mail: sales@ravelfire.com; Web: www.ravelfire.com

UAE

RAVEL DMCC,
Unit No: G30, DMCC Business Center,
Level No 13, AG Tower, Dubai, UAE.
E-mail: sales@raveldmcc.com

USA

RAVEL AMERICAS INC.,
2855 NW 112th Ave ST#2 Miami,
Doral, Florida 33172, USA.
E-mail: sales.us@ravelfire.com